



USB to Serial 990.004 Micro Converter



Technical Specifications

FT232RL - FTDI: versatile and powerful conversion chip.

- **Serial Levels:** 3.3V or 5.0V selectable
- **USB Plug:** Mini B
- **USB Standard:** 1.1 and 2.0 compliant
- **5V OUT - Output Power:** about 300 mA available from the USB Bus.
- **Dimensions:** 18 x 25mm - max height 8 mm

Features

- TX and RX LEDs** to monitor Serial activity
- 3.3V and 5V** serial levels
- DIL form factor** to use the Board on Bread Boards or other 2.54mm pitch standard boards
- 5 pin 2.54mm pitch** front connector for easy and fast connection
- Compact Size** ideal for prototype or production
- Hardware Handshaking** full supported

Layout

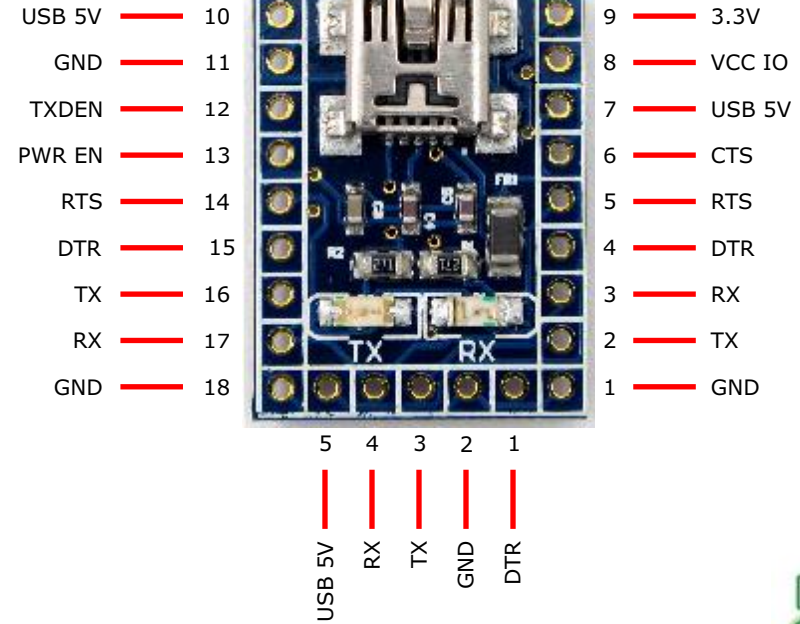

Description

This is a very compact board for USB to TTL Serial conversion. Based on the popular and powerful FTDI FT232 chip, you can find drivers for all of the most common Operative Systems. The module works on 5.0V and 3.3V systems, pin 7, 8 and 9 are used for voltage setting. All the most used signal pins are available, a useful TX Enable pin is available for RS485 or similar networks. Two useful LEDs allow constant monitoring of the TX and RX signals, useful for fast troubleshooting. You can connect the Board in several methods, some useful headers are included in the kit. You can also solder the wires directly to the needed pins. Soldering two 9 pin headers (included) the module can be used as a 2x9 DIL chip on standard breadboards and perboards. Simply connect the device to a computer, install the proper drivers and a virtual serial port will be available on your system.

DROIDS SAS
VIA NANNARELLI 41
00139 ROMA ITALY
www.droids.it
info@droids.it



Tie Pin 8-9 for 3.3V
Tie Pin 7-8 for 5.0V

Solder the included jumper and cut the exceeding leads. Or you can connect the pins on your application board.

Content of the package

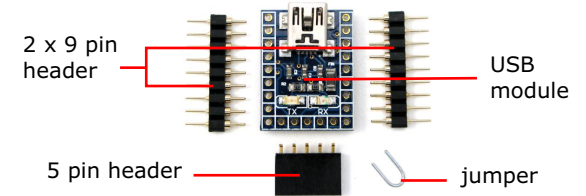

Applications

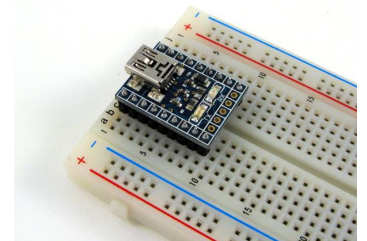
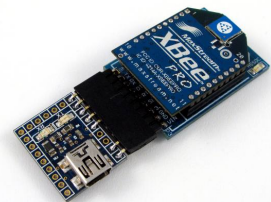

Note

Remember to tie pin 9-8 or 7-8 to use the device at 3.3V or 5.0V TTL serial level.
Drivers and documentation for the FT232RL chip: www.ftdichip.com