

## Bluetooth® Module RN-41 Class 1, 2.0 EDR

### OVERVIEW

- Fully Qualified Bluetooth 2.0/1.2/1.1 module, using CSR BC04 External
- Class 1 high power amplifier, on Board ceramic RF chip antenna.
  - Conforms to FCC, CE and the EMI standard of each country.
  - Modular Approval: FCC ID: T9J-RN41-1, ICS: 6514A-RN411, CE: 0681
  - Environmentally friendly, RoHS compliant.
- Bluetooth SIG Qualified as End Product Listing : **B013180**  
(no additional testing or fees required )
- UART, USB, PCM interfaces available to various applications.
- SPP stack: sustained data rates- 240Kbps (slave), 300Kbps (master).
- 8MB on board flash, HCI, or SPP software stacks available.
- Embedded Bluetooth stack profiles included (*requires no host MCU stack*):  
BCSP, SPP, DUN, GAP SDP, RFCOMM, and L2CAP protocols.



### FEATURES

- Baud rate speeds: 1200bps up to 921Kbps, non-standard baudrates can be programmed.
- Class 1 radio, 330' (100m) distance, 15db output transmitter
  - Low power modes 50mA TX, 40mA RX (connected), 10ma (sniff mode), 2ma (idle ), 250ua(sleep)
- UART local and over-the-air RF configuration
- Small-form factor SMT radio modem 13mm x 26mm.
- Auto-discovery/pairing requires no software configuration (instant cable replacement).
- Auto-connect master, and character based trigger modes.
- Operating temperature range: -40~+85°C.
- Secure and robust communication link
  - ✓ FHSS (Frequency Hopping Spread Spectrum)
  - ✓ 128 bit encryption
  - ✓ Error correction schemes for guaranteed packet delivery

### SPECIFICATIONS

Item	Specifications
Frequency	2402 ~ 2480MHz
Modulation	FHSS/GFSK
Channel intervals	1MHz
Number of channels	79CH
Transmission rate (over the air)	721kbps-2.0Mbps
Receive sensitivity	-80dBm typ.
Output level (Class1)	15dBm max.
Dimensions	
	With antenna

## Block Diagram

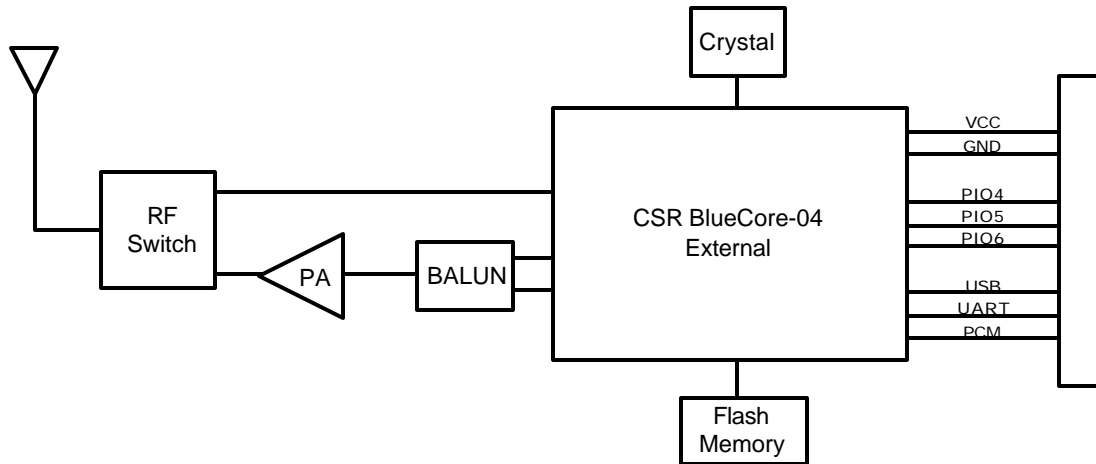

## Electrical Characteristics

	Min	Typ.	Max.	Unit
Supply Voltage (DC)	3.0	3.3	3.6	V
RX Supply Current	-	35	60	mA
TX Supply Current	-	65	100	mA
<b>Average power consumption</b>				
Standby/Idle (default settings)	-	25	-	mA
Standby/Idle (lowest power)	250uA	2.5	-	mA
Connected(normal mode)		30		mA
Connected( low power Sniff)		8		mA

## Operating and Environmental Conditions

Operating Temperature Range	-40 °C ~ 85 °C
Storage Temperature Range	-40 °C ~ 85 °C
Relative Humidity (Operating)	≤90%
Relative Humidity (Storage)	≤90%



## DESIGN CONCERNS

---

**1. RESET circuit** RN-41 contains a 1k pullup to VCC, the polarity of reset on the RN41 is ACTIVE LOW. A power on reset circuit with delay is OPTIONAL on the reset pin of the module. It should only be required if the input power supply has a very slow ramp, or tends to bounce or have instability on power up. Often a microcontroller or embedded CPU IO is available to generate reset once power is stable. If not, there are many low cost power supervisor chips available, such as MCP810T, MCP102/121, and Torex XC61F.

**2. Factory reset PIO4.** It is a good idea to connect this pin to a switch, or jumper, or resistor, so it can be accessed. This pin can be used to reset the module to FACTORY DEFAULTS and is often critical in situations where the module has been mis-configured.

**3. CONNECTION status.** PIO5 is available to drive an LED, and blinks at various speeds to indicate status. PIO2 is an output which directly reflects the connection state, it goes HIGH when connected, and LOW otherwise.

**4. Using SPI bus for flash upgrade.** While not required, this bus is very useful for configuring advanced parameters of the Bluetooth modules, and is required for upgrading the firmware on modules. The suggested ref-design shows a 6pin header which can be implemented to gain access to this bus. A minimum-mode version could just use the SPI signals (4pins) and pickup ground and VCC from elsewhere on the design.

## REFLOW SOLDERING PROFILE

---

Lead-Free Solder Reflow

Temp: 230 degree C , 30-40 seconds, Peak 250 degree C maximum.

Preheat temp: 165 +- 15 degree C, 90 to 120 seconds.

Time: Single Pass, One Time

## ORDERING INFORMATION

---

Part Number	Description
RN-41	Standard Application firmware Enabled (SPP/DUN Master and Slave)
RN-41-H	HCI over H4 UART at 115K Bps (Application firmware disabled)
RN-41-U	HCI over USB port (USB slave device at 12Mbps rate).

For other configurations, contact Roving Networks.